

POTATO TECHNOLOGY  
SUGAR BEET TECHNOLOGY  
VEGETABLE TECHNOLOGY

**GRIMME**  
*HARVESTING SUCCESS!*

# SE 150/170-60

2-row, off-set pulled potato harvester with large bunker





# Welcome to the luxury class: strong, stronger, the SE 150/170-60!

Absolutely efficient, sturdy and reliable – the SE 150/170-60 from Grimme. The 2-row, off-set pulled bunker digging machine has been specially designed for highest acreage performance and efficient lifting at rapidly changing locations. Offering ease of operation, adjustment and maintenance, this luxury class machine can also be effortlessly used on difficult terrain. Work is greatly facilitated by a generously dimensioned

vision field thanks to the intake's arrangement on the right-hand side, as well as a long picking table offering ample space. 2 main webs working hand in hand guarantee highest separating performance and gentle product handling: only the use of 2 webs can prevent roll-back effects and optimise the sieving performance of the soil that is carried along on the 1<sup>st</sup> web. Afterwards, the machine

continues to sieve the soil via the 2<sup>nd</sup> main web, the deviner web separates the haulm and transfers the harvest flow gently onto further separators – all in one work step! Low angled main webs, minimised drop heights and a soft bunker floor guarantee the most gentle harvest treatment inside the machine. A strong range for your harvest: the SE 150/170-60!





## Table of contents

The intake technology in overview	4
Increased performance – sieving tools, haulm separation and separators	8 – 9
Easy sorting and picking	10 – 11
The moving floor bunker – for gentle unloading	12 – 13
Drives, drawbar, tyres, machine control and digital technology	14 – 15
The self-propelled harvester SF 150/170-60	16 – 17
Technical data	18









## Strong performance: geared to gentle harvest handling from the word go



The off-set intake unit on the right-hand driver's side makes for easy machine handling. The pulled ridge intake with large, spring mounted coulters and 2 haulm feed-in rollers facilitates trouble-free digging at intake widths (disc coulters distance) of 540, 580, 600 and 620 mm. The bearing pressure of the diablo roller on the ridge can be optionally adjusted. An automatic diablo pressure regulation or a hydraulic ridge relief with pressure adjustment at the control terminal is optionally available. The pressure regulation prevents unnecessary sealing on tough and very wet soils as well as potato damage caused by stone content. At the same time, it retains the ridge structure on light soils (1).



Ideal for high haulm content: the optional 2<sup>nd</sup> disc coulters (2). The golden middle course: profit from the automatic center steering (option) (3). The drawbar is hydraulically controlled via two sensors which are clamped on the diablo roller frame. With the hydraulic ridge relief (4), you achieve a clear reduction of the diablo pressure (option).



Well picked up: use the 2-blade share for tough soils and the 3-blade share for medium and light soils. Protect the shares with optional available stone protection (5). Easily solved: adjustment of the shares for an ideal digging depth either by means of an adjusting screw (6) or optionally in a hydraulic and infinitely variable manner (7) from the tractor seat.

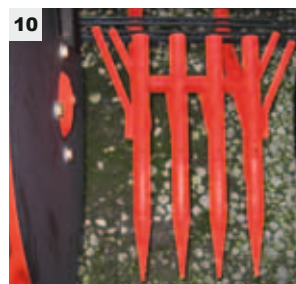

Easily obtaining a triple benefit: the optionally available vegetable intakes for onions, celery or carrots (8–10).

Windrow intake with shares and rubber roller or for heavy soils with rotor shaft

Vegetable intake: through typed share with support wheels. Special adaptations are possible.

Carrot intake: large-dimensioned support wheels with adjustable distance, mechanical depth adjustment and one- or two-row carrot share. Customised row widths and distances are possible.

# Individual solutions are ideal solutions – The Grimme Option

Harvesting conditions vary from campaign to campaign: different weather conditions, different soils, a multitude of potato types and many, many

other factors. – How you can achieve an optimum result despite all this? With the Grimme options that are available for the SE 150/170-60!

Numerous adjustment and equipment make it possible to adapt the digger accurately to your requirements.

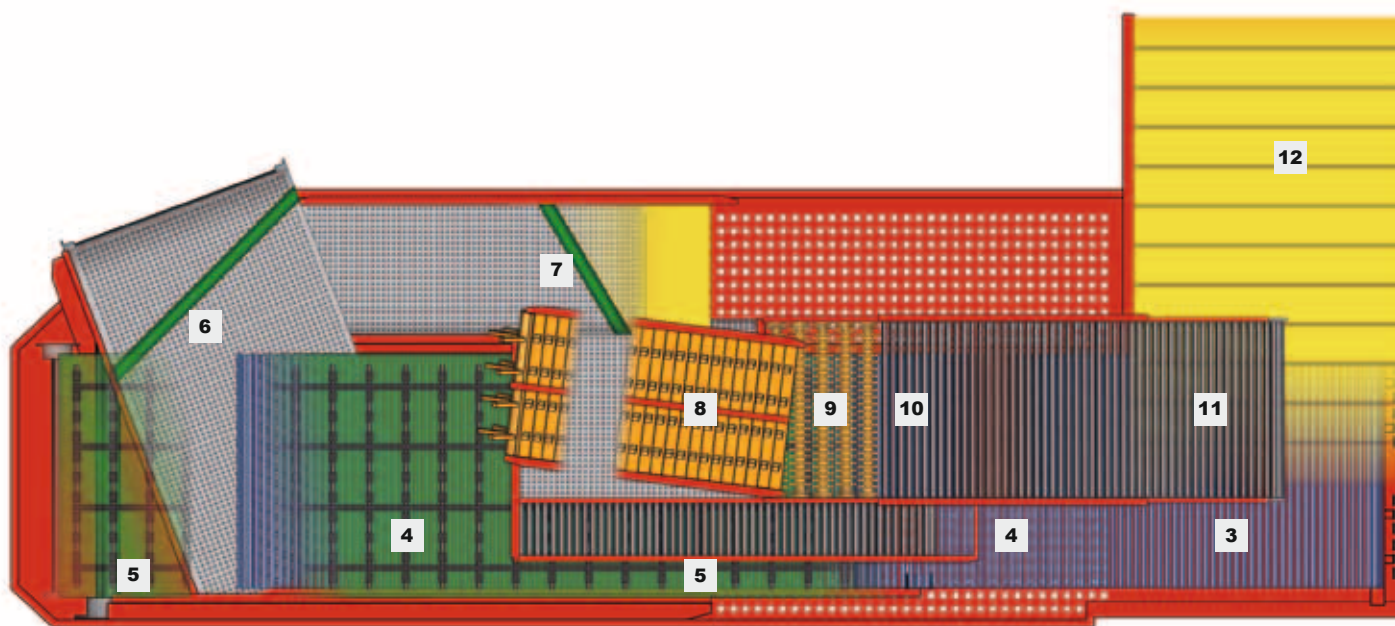
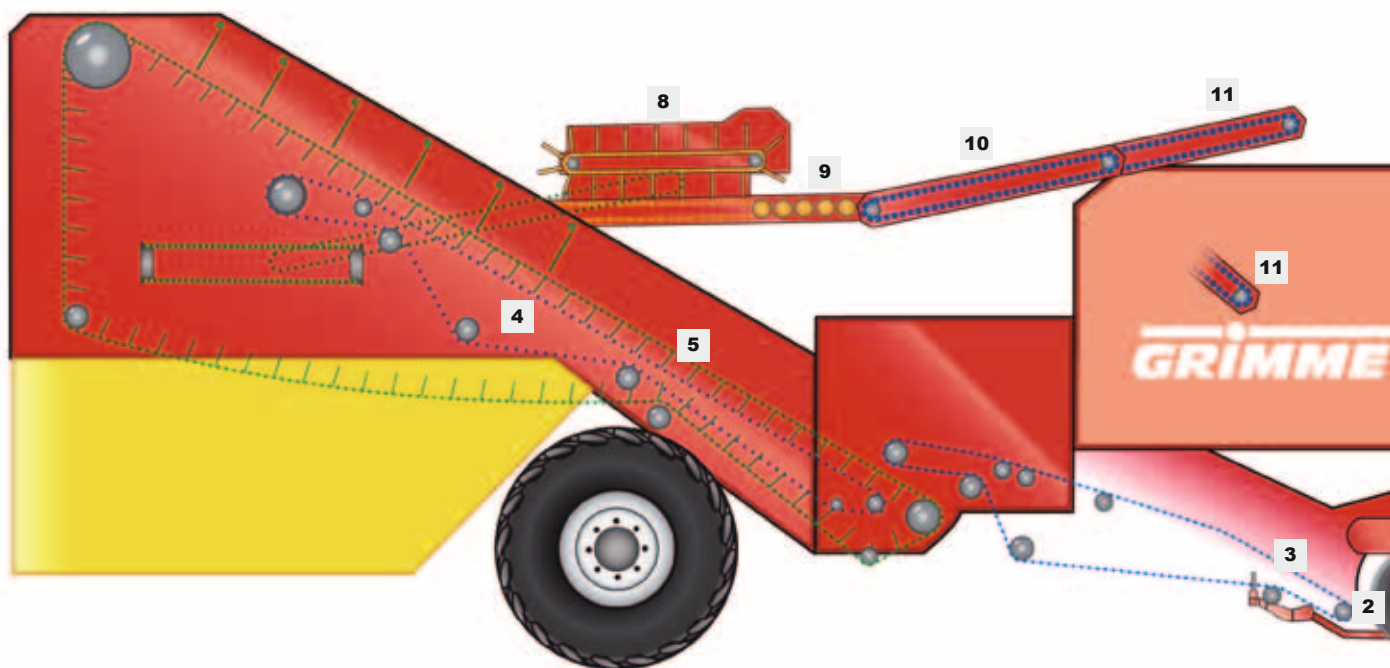

- |   |   |   |  |
|---|---|---|--|
| <b>1</b> Drawbar                        | <b>4</b> 2 <sup>nd</sup> main web                 | <b>7</b> 2 <sup>nd</sup> double extracting roller | <b>10</b> Picking web                      |
| <b>2</b> Intake                         | <b>5</b> Deviner web                              | <b>8</b> Separator                                | <b>11</b> Flexible bunker filling elevator |
| <b>3</b> 1 <sup>st</sup> short main web | <b>6</b> 1 <sup>st</sup> double extracting roller | <b>9</b> Pre-grading rollers (option)             | <b>12</b> Moving floor bunker              |



ns!

ent versions  
ng unit

# Keeping the important, removing the unimportant – the sieving systems

## 1<sup>st</sup> and 2<sup>nd</sup> main web (rubber roller drive)

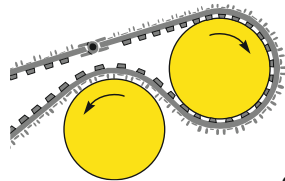

Ideal combination of 1<sup>st</sup> short and 2<sup>nd</sup> long main web: optimum input of earth into the machine.

Quiet, long-life, specially rubber coated drive rollers. The drive underneath the bars is standard.



## Intake web (option)

The infinitely hydraulically driven intake web, and with its additional drop – increases separation and performance.

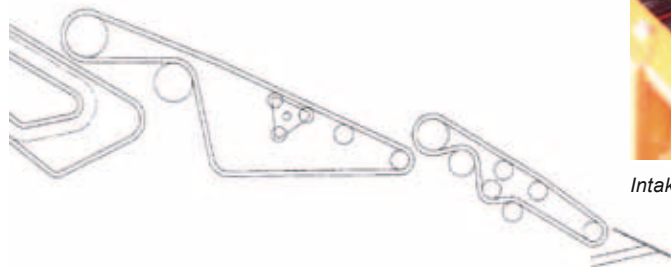

Intake web

## Patent High cam belt

Full potato protection by high cams: the particularly gentle and damage-free way of conveyance. Your tubers are really pampered by these belts and do not come in contact with any metal parts.

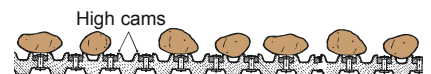

## Hydraulic swinging agitator (option)

For even more efficiency on the 1<sup>st</sup> main web. The effect of the hydraulic swinging agitator can be individually adjusted via the control terminal.



## Triangular rollers in the main web channel

The triangular rollers bring even more sieving performance. The V2A-sheets in the swing frame (option) are ideal for everyone appreciating the benefit of a reduced amount of earth sticking to the side panels and even gentler product handling due to the reduced friction effect.

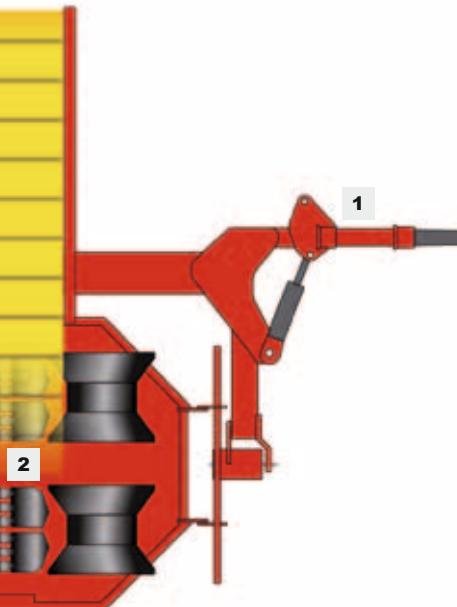
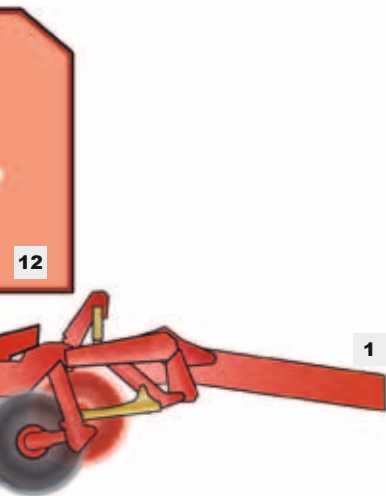

# Original Grimme know-how: the multifunctional web. Sieve more. Separate more. Convey more.

**Patent** Patented multifunctional web

Sieving, separating, conveying: three from one with the multifunctional web. Gentle crop flow from the 1<sup>st</sup> to 2<sup>nd</sup> main web and gradually conveyed in pockets.

**Sieving** The 2<sup>nd</sup> main web effectively and gentle separates the soil and transfers the crop to the separator.

**Separating** The close deviner web runs over the 2<sup>nd</sup> main web, separates the haulm from the crop flow and discharge it onto the field. Up to 3 scraper rollers can increase the separation. Protection via safety clutch is standard. The spring suspension of the scraper combs ensures a long service life; one additional scraper comb is optionally available.

**Conveying** Gentle crop handling pockets arise in combination with the 2<sup>nd</sup> main web and deviner web. They convey the potatoes in "portions" onto the 1<sup>st</sup> separator. That keeps the crop flow calm, thus preventing damage to the tubers caused by the conveyance process.



The most gentle crop handling possible: deviner web with soft PU-drivers (distances optional 200 mm, 280 mm)

**Sieving**



**Separating**



**Conveying**



Effective trash separation and gentle crop transfer at once

**1<sup>st</sup> and 2<sup>nd</sup> double extracting roller**

The efficient separation of residual haulm and smaller trash is effected via the 1<sup>st</sup> and 2<sup>nd</sup> double extracting roller and hedgehog webs, which are available with different bar pitches. For an optimum adaptation to the harvested produce, the distance between both double extracting rollers and the picking belt can be adjusted. A hydraulic adjustment is optionally available for the 1<sup>st</sup> double extracting roller. For a fast alteration on changing soils, the hedgehog webs and the double extracting rollers can be adjusted in an infinitely variable manner via the hydraulic drive. An additional plus: the high degree of operational reliability resulting from reciprocal roller cleaning without the use of scrapers.



1<sup>st</sup> double extracting roller



Double extracting roller (A), optional spiral roller (B) to increase the separating performance



2<sup>nd</sup> double extracting roller



## Good separated is well picked

### Type UB – for soils with a high clod but low stone content

The hedgehog web is either available with plates for light to medium soil as well with bars for heavy soil. The speed of finger belts and hedgehog web is adjustable in an infinitely variable manner. The finger belts can be separately adjusted in a hydraulic manner and their speed is also adjustable.



Type UB: best separating results on soils with a high clod but low stone content

### Type SB – for soils with a high stone content

Optimum adjustment possibilities on different soils thanks to the hydraulic drive of the hedgehog and brush webs. The novelty: pre-separation already takes place on transfer to the hedgehog web. As the web is slightly curved, the potatoes are gently taken to the brush web. Stones and heavy clods are already retained at this point and are neatly separated. The result: a clearly increased separating result.



Type SB: best separating results on soils with high stone content thanks to an innovative kinetic stone separator

### Type NB – for soils with little trash

The speed of the extended, hydraulically driven picking web can be adjusted in an infinitely variable manner from the control terminal at the picking web or from the tractor seat. A mechanical levelling adjustment facilitates adjustment to the harvested crop and the soil conditions. Triangular rollers underneath the picking web increase the sieving performance and distribution; the intensity can be controlled via hand lever. In addition, a hydraulic rotor agitator is optionally available.



Type NB: best separating results on soils with a low trash content

### Type NB with 3<sup>rd</sup> hedgehog web and 3<sup>rd</sup> scraper roller. for increased performance on soils with low trash content

The separator type NB is supplemented by another hedgehog web with scraper roller. This once more clearly increases the output. The levelling of the entire separator can be adjusted to improve the distribution of the potatoes on the picking web.

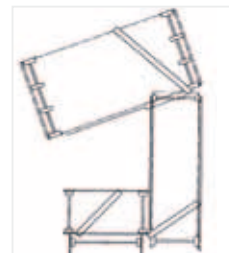

Type NB with 3<sup>rd</sup> hedgehog web and 3<sup>rd</sup> stripper roller – for an even better performance on soils with low trash content

### **NEW** XXL separator for maximum separating performance

XXL separator consists of: extended first separator (1); widened second separator (2) and three instead of two scraper rollers (3) on the 1<sup>st</sup> separator. The special arrangement of the scraper rollers in a flat angle (4) provides up to 40 % more continuity and gentle yet powerful deflection of large quantities of potatoes.

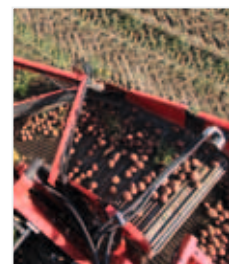
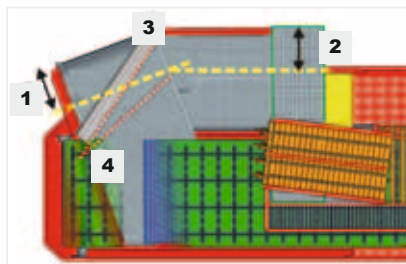

Impressive product flow even with large amounts of potatoes







# Ensuring good results and best harvest quality!



When using the UB or SB separator, 5 hydraulically adjustable pre-grading rollers reliably separate undersize (1).

On the NB separator, a central adjustment device permits the infinitely variable adjustment of the 5 pre-grading rollers (2) over a distance of 0 – 40 mm.

A roller speed which increases in direction of flow is gentle on the harvested crop.



Picking table with virtually flat surface: up to 6 persons can be deployed at the picking web (3) under best ergonomic working conditions.

Everything under control: with the control terminal GBT 817, personnel are able to control all important picking functions. Thanks to their hydraulic drive, the speed of the separators and the picking web can be adjusted in an infinitely variable manner. This facilitates an optimum adaptation to harvested quantity and amount of trash. The picking staff can stop the picking belt by means of a stop button and transmit an acoustic warning signal to the driver (4).



Well thought out: a transverse discharge conveyor belt transports the trash underneath the picking web (5). This prevents it from being added back to the harvest flow.

Stone box with unloading web (option) (6). Filling is effected via favourably arranged dropping shafts. Hydraulic unloading is possible from the tractor seat and from the picking belt.



Minimal drop steps during moving floor bunker filling (7/8) thanks to hydraulic raising and lowering of the final conveyor. Benefit from the automatic final conveyor (option): as the material cone in the bunker increases, the final conveyor is raised automatically in small steps to achieve a continuously low drop step.



MOVING FLOOR BUNKER

## A lot of holding capacity comes inclusive of a lot of know-how

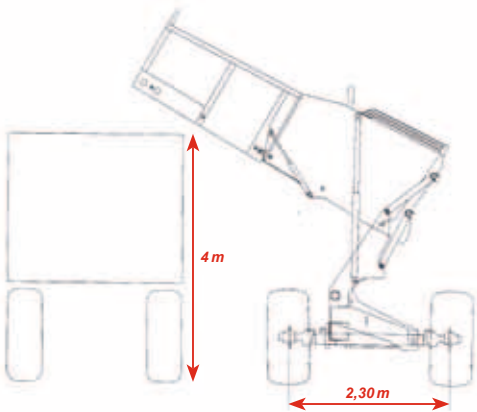

6-ton moving floor bunker (series): the optionally available filling optimisation allows the bunker capacity to be increased by 300 kg to 6,300 kg.

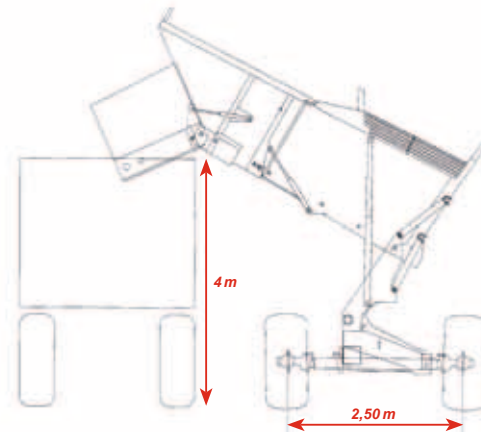

Option: the 7.5-ton large bunker with bunker head lowering clearly increases the impact force. Important: can only be used with wide axle and drawbar ball hitching, the overall width increases to 3.30 m due to the larger track width (please observe country-specific road traffic regulations).

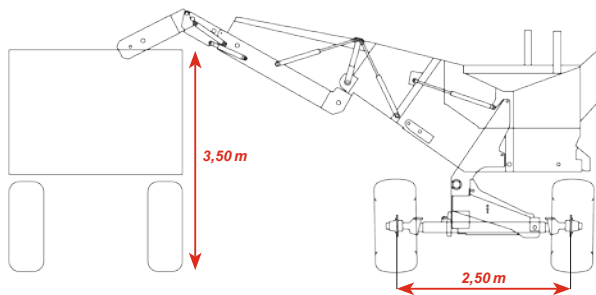

Option: 5.8-ton transfer bunker for convenient unloading while travelling. With the overloading bunker it is possible to quickly and easily fill trailers with a maximum side wall height of 3.50 m.







*Drop-step optimized transfer: moving floor bunker with head end lowering with optimized drop height while filling the trailer (option) (1).*

*Unloading while travelling: with the overloading bunker (2) for simple and fast filling of trailers with up to 3.50 m height (option).*



*A soft landing thanks to the potato box filling chute with rubber buffes: for a gentle filling of trailers (option) (3)*

*The hydraulic device to raise bunker end to clear of crop or optimum final filling of high trailers to increase unloading speed (option) (4).*



*Convenient: the BIG BAG filling device combined with the potato chute and rubber baffle (option) (5)*

*More in it for you: with the automatic filling system (option) (6), manual operation is no longer necessary; the moving floor bunker's holding capacity is used in an optimum manner.*



*Brilliant option for gentler crop handling: the moving floor bunker with stainless steel sides prevents soil sticking to the sides in wet conditions (option) (7).*

*The gentlest product handling possible thanks to the soft bunker floor, short unloading times thanks to the wavy bunker floor shape (8)*

*For all who are thinking big: the large-dimensioned bunker can be hydraulically raised with the push of a button to a maximum outlet height of 4.20 m for convenient transfer loading. The connecting rod suspension achieves virtually constant transfer distances at different raising heights. The wavy bunker floor shape of the soft bunker floor ensures short unloading times. Two speed levels are available for fast residual emptying.*



*Well thought out down to the smallest detail: the inside position of the motors of the moving floor bunker (9) do not only work reliably, but are also protected against damage due to collision.*





**DRAWBAR AND DRIVES**

# A good connection: strong drives, sturdy drawbar

That's the way to work: the maintenance-free drive of the 2<sup>nd</sup> main web and the haulm web (1) provide for a quiet machine. The excellent visibility onto the separating devices facilitates work at the picking table.



Well coupled for all occasions: a drawbar ball coupling is optionally available. Alternatively, the machine is reliably hitched underneath the power take-off shaft connection. All towing eyes are height-adjustable so they can be adapted to different tractor models.

-  Drawbar eye ø 40 mm
-  Hitch or Piton fix ø 50 mm
-  Ball bearing coupling ø 80 mm (option)

The hydraulic lateral adjustment of the drawbar (2) and the central arrangement of the articulated shaft facilitate a quiet run of the drive line, thus guaranteeing a long service life.



Always safe on the road – with the optimum tyres (3)



- 600/55-26.5 (series)
- 710/45-26.5 (option)
- 710/50-26.5 (option)
- 710/50-30.5 (option)
- 800/45-30.5 (option)
- 710/50-30.5 (option)

Three-stage gearbox (option) (4): adaptation of the machine to delicate harvested produce – reduction of the start shock



Advancing under adverse conditions thanks to hydrostatic wheel drive (5)



Hydraulic steering axle: high degree of manoeuvrability – short turning manoeuvres. Always in balance: with the hydraulic levelling which is standard (6); optional: automatic levelling



**MACHINE CONTROL AND DIGITAL TECHNOLOGY**

# Consistent operation for top results

## Visual Protect



Reacting faster: the optional CAN bus-controlled video monitoring system VISUAL PROTECT facilitates an all-round function monitoring of your harvesting machine. If there is a problem in the machine, the screen automatically switches to the corresponding camera.





## Harvesting success – at the touch of a button: Grimme digital technology

For maximum operator convenience, a digitally-controlled control terminal is available: the Grimme SKE-S. It does not only provide added convenience, but also maximum reliability. In addition, all functions can be conveniently checked and set from the driver's seat. With the optionally available control terminal VC 50 (5), important parameters such as overall hectare performance, operating hours,

daily performance, etc. are indicated on the display in a clearly laid out manner. The integrated error diagnosis system provides you with the best possible ease of maintenance. The additional functions include among others the function sequence programming "Start of field" and "End of Field". – In this manner you can get the maximum out of the SE 150/170-60 under any harvesting conditions!



Control terminal SKE-S



Convenient operation as a standard: use the combination of VC 50 terminal and GBX terminal for intuitive operation (1).

For a perfect one-hand operation of the machine, we offer an optional joystick with freely selectable setting of the individual keys (2).



World-wide unique: the control concept CCI 200 (3) for ISOBUS compatible agricultural machines that spans several manufacturers has been co-developed by Grimme (option).

Convenience at the push of a button: the optionally available CLEAN CONTROL (4) facilitates the simultaneous control of selected separator assemblies, for instance to briefly turn up performance to 100 % for cleaning purposes.



By combining digital technology with the optionally available control terminal VC 50 (5), further functions can be conveniently controlled from the tractor seat or from the picking table: e.g. the infinitely variable adjustment of the 6 retainer combs (3 top, 3 bottom) on the wide-meshed haulm chain, the infinitely variable depth adjustment of the digging share, the infinitely variable adjustment of the inclination or the distance height between the 1<sup>st</sup> and 2<sup>nd</sup> double extracting roller or function sequence programming "Start of field" and "End of field". Due to the ergonomic arrangement, control terminal and intake unit can be viewed simultaneously.



# **Gets the most of it for you: the self-propelled harvester SF 150/170-60**











## Technical data

	<b>SE 150/170-60</b>
<b>Length</b>	11,200 mm (with drawbar)
<b>Width</b>	3,000 mm (6-ton bunker) or 3,300 mm (7-ton and 7.5-ton bunker)
<b>Height</b>	3,700 mm (with standard tyres)
<b>Weight (empty)</b>	Total weight 9,350 kg, axle load 7,650 kg, 5 <sup>th</sup> -wheel load 1,700 kg (all weights for basic equipment)

	<b>Basic equipment</b>	<b>Options</b>
<b>Drawbar</b>	Towing eyes Ø 40 or 50 mm, eye/hitch	Hydraulic drawbar steering, ball bearing coupling with 80 mm diameter
<b>Power drive train</b>	Main drive: low-maintenance gearbox drive incl. articulated shafts, drive speed 540 rpm or 1,000 rpm.	Three-stage gearbox
<b>Intake</b>	Pulled intake unit, 4 pulled coulter discs, spring-mounted, optionally 540 mm, 580 mm or 620 mm distance, 2 cutaway discs, 2- or 3-blade share, 2 pulled diablo rollers, 2 haulm feeder rollers, diameter 400 mm	Ridge centering, hydraulic share depth guidance, stone protection for cutaway disc, automatic ridge relief, automatic diablo pressure regulation, intake web with hydraulic speed adjustment, 2 <sup>nd</sup> coulter disc right hand, rubber fan drum for windrow intake, 2 haulm deflector slides
<b>1<sup>st</sup> main web</b>	Channel width 1,500 mm: 1,450 mm wide, 2,750 mm long, optionally 28, 32, 35, 40, 45 and 50 mm; Channel width 1,700 mm: 1,650 mm wide, 2,750 mm long, optionally 28, 32, 35, 40, 45 and 50 mm	V2A-sheets in the main web channel, hydraulically driven swinging agitator with infinitely variable speed adjustment, main web channel width 1,700 mm
<b>2<sup>nd</sup> main web</b>	Channel width 1,700 mm: 1,650 mm wide, 3,900 mm long, optionally 28, 32, 35, 40 and 44 mm	Slip monitoring
<b>Haulm separation</b>	Scraper unit with rubber covered retainer combs, haulm web 1,750 mm wide, 5,400 mm long	Hydraulic adjustment of the retainer combs
<b>1<sup>st</sup> separator assembly</b>	Transverse hedgehog web with double extracting roller, inclination adjustable, 1,300 mm wide, 2,340 mm long	Slip monitoring, hydraulic height adjustment of the double roller scraper, electric speed adjustment
<b>2<sup>nd</sup> separator assembly</b>	Type UB, NB: hedgehog web running in direction of travel with double extracting roller, 730 mm wide, 2,380 mm long Type SB: feed web, closed design, 730 mm wide, 1,300 mm long	Electric speed adjustment
<b>3<sup>rd</sup> separator assembly</b>	Type UB: transverse hedgehog web, inclination mechanically adjustable, 1,300 mm wide, 1,450 mm long, double finger web (double) with trash channel Type SB: 2 transverse hedgehog webs, hedgehog web long: 650 mm wide, 2,350 mm long; hedgehog web short: 650 mm wide, 1,450 mm long; with trash channel Type NB hedgehog web: transverse hedgehog web, inclination mechanically adjustable, with double extracting roller, without trash channel	Type UB/SB: electric speed adjustment Type NB hedgehog web: 3 <sup>rd</sup> hedgehog web
<b>Picking table</b>	With warning system, UB/SB 1,100 mm wide, NB without hedgehog web 900 mm wide, NB with hedgehog web 1,100 mm wide, NB with grader assembly and without hedgehog web 1,000 mm wide, trash channel (UB, SB) 340 mm wide, standing platform for at least 2 x 2 persons (UB, SB), hydraulic drive of the picking belt	Stone box with lateral cross conveyor web, roller pre-sorting with container for small potatoes
<b>Bunker</b>	Outlet height: 4,200 mm, capacity: 6,000 kg, 2-steps for drive, adjustable in an infinitely variable manner	Holding capacity: 6,300 kg incl. filling optimisation, potato hopper with drop height reducer, hydraulic folding device for potato hopper with drop height reducer, filling automatic, 7.5-ton bunker (machine width 3,300 mm), 5.8-ton bunker with direct transfer loading (machine width 3,300 mm), adjustable bunker end section, BIG BAG with potato hopper with drop height reducer, automatic final conveyor
<b>Axle</b>	Hydraulic steering axle, Hydraulic levelling	Axle centre detection, automatic levelling Hydraulic wheel drive
<b>Tyres</b>	600/55-26.5	710/50-30.5, 600/55-26.5 Michelin-Cargobib or 710/45-26.5
<b>Machine control system</b>	CAN-bus electronic system with diagnosis option	VC 50 control terminal, VISUAL-CONTROL CCI 200 terminal, colour monitor with colour cameras, VISUAL PROTECT

Your Grimme Partner for advice and service:

No claims can be raised in respect of texts, illustrations, technical specifications, dimensions and weights, equipment as well as performance specifications. They are approximate and non-binding. Changes in the course of technical enhancement are possible at any time.